

# Motor Purge & Pressurisation Systems for High Temperatures

D670 – Flow rates up to 1,500 NI/min (53 SCFM)

D770 - Flow rates up to 6,000 NI/min (212SCFM)

D870 - Flow rates up to 14,000 NI/min (494 SCFM)



## Features

- **High temperature operation** : Certified for use at 60°C (140°F) ambient & 70°C (158°F) purge air.
- **User Selectable Settings** :
  - D670**: 2 user selectable purge flow rates (1,000/1,500 NI/min) (35/53 SCFM)
  - D770**: 5 user selectable purge flow rates (2,000/3,000/4,000/5,000/6,000 NI/min) (71/106/141/177/212 SCFM)
  - D870**: 6 user selectable purge flow rates (7,000/ 8,000/10,000/12,000/14,000/20,000 NI/min.) (247/283/353/424/494/706 SCFM)
- **Purge time**: 1-99 minute (-0/+3 seconds tolerance). Suits a wide variety of machine frames sizes
- **Clear Visual Status Indication** : Local indicators for "Alarm/Pressurized" and "Purging".
- **Continuous Operation through Closed Loop Automatic Pressurization System (CLAPS)** : Eliminates spurious trips on start-up or load change.
- **316L Stainless Steel enclosure & fittings** : Excellent resistance to corrosion for harsh environments.
- **Temperature control**: Vortex cooler with dual thermostats.
- **Full Compliance with Standards** - Direct purge flow measurement at Relief Valve exhaust orifice.
- **Global Approvals** – IECEx; ATEX; INMETRO; EAC

## Operation

The Motor Purging and Pressurization control system has been designed for use on large electrical machines located in a very low temperature hazardous locations.

The system delivers a high purge rate for a given duration (as defined by machine designer and Notified Body) prior to start-up, to purge any potentially explosive gases from the machine. After purge, the system automatically switches to leakage compensation mode for normal operation. Expo's Closed Loop Automatic Pressurization System (CLAPS) automatically compensate for pressure variations in the machine during start-up or through temperature variations during operation. The system enables the machine to continuously operate at a set over-pressure, saving considerable time during test and commissioning, simplifying normal operations.

## System Components

The system comprises the Control Unit (CU) and the Relief Valve (RLV). The Control Unit contains the pneumatic logic to monitor and control air flow, pressure and purge timing, and provides the system outputs. For high temperature applications, the logic compartment and incoming logic air are maintained at a temperature < 55°C with a built-in cooler.

The RLV measures purge flow at the outlet and provides over-pressure protection for the machine through a patented magnetically - set exhaust valve with integrated spark arrestor.

## Explosion Protection

Hazardous Area classification:

IECEx, INMETRO Zone 1, Group IIC T4 Gb

IECEx, IN METRO Zone 21, Group IIIC T100°C Db

ATEX Category 2 G, Zone 1, Group IIC T4 Gb

ATEX Category 2 D, Zone 21, Group IIIC T100°C Db

Ambient temperature: -20°C to +60°C (-4°F to 140°F)

Purge gas temperature: -20°C to +70°C (-4°F to 158°F)

## System Data

Control Unit  
(CU)

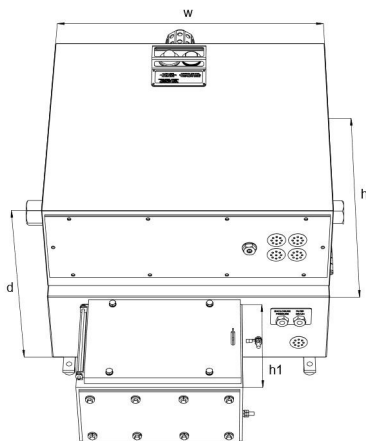

Relief Valve  
(RLV)

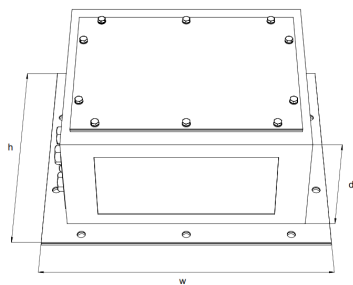

| Dimensions | D670<br>CU / RLV | D770<br>CU / RLV  | D870<br>CU / RLV   |
|------------|------------------|-------------------|--------------------|
| Width w    | x / 230mm (9")   | x / 330mm (13")   | x / 540mm (21.3")  |
| Height h   | x / 200mm (8")   | x / 280mm (11")   | x / 410mm (16")    |
| Height h1  | / N/A            | / N/A             | / N/A              |
| Depth d    | x / 134mm (5.3") | x / 136mm (5.4")  | x / 292mm (11.5")  |
| Weight     | x / 4kg (8.8lbs) | x / 7kg (15.4lbs) | x / 23kg (50.7lbs) |

**Enclosure & Mounting:** Housing & external process connections 316L stainless steel. Wall mounting lugs provided for fitting to machine.

### Process Connections:

D670: Purge inlet: 1/2" NPT (F), recommended supply pipe: 1" I.D. min. Purge outlet to machine: 1" NPT (F).

D770: Purge inlet: 1" NPT (F), recommended supply pipe: 1" I.D. min. Purge outlet to machine: 1" NPT (F).

D870 Purge inlet: 2" NPT (F), recommended supply pipe: 2" I.D. min. Purge outlet to machine: 2" NPT (F);

Reference point & signals: 1/8" NPT (F).

Purge gas: Clean Dry Air or Inert Gas.

## Technical Specifications

### D670MOTORSYS-E:

Description: 3XLC/ss/ET/OV/PA/PC/D670  
Purge flow rate: 1,000-1,500 NI/min (35-53 SCFM)  
Leakage compensation: Up to 500 NI/min (18 SCFM)  
Compressed air supply: 4-8 barg (58-116 psi);

### D770MOTORSYS-E:

Description: 5XLC/ss/ET/OV/PA/PC/D770  
Purge flow rate: 2,000-6,000 NI/min (71-212 SCFM)  
Leakage compensation: 1,900 NI/min max (67 SCFM)  
Compressed air supply: 4.2-10 barg (61-145 psi)

### D870MOTORSYS-E:

Description: 7XLC/ss/ET/OV/PA/PC/D870  
Purge flow rate: 7,000-14,000 NI/min (247-494 SCFM)  
Leakage compensation: 5,100 NI/min max (180 SCFM)  
Compressed air supply: 4.5-8 barg (65-116 psi)

### Common Data

Intrinsically safe Electronic Timer, range 1-99 mins. battery powered. Option to use Electro Pneumatic Power Supply (EPPS)  
System outputs are volt-free contact closures terminated in Exe Junction Box, with:

Power= 250 Vac 4 Amp (AC15) DPNO Ex d IIC T6  
Alarm = 250 Vac 4 Amp (AC15) SPCO Ex d IIC T6  
Intermediate Pressure/Pre-alarm = 250 Vac 4 Amp (AC15) SPCO Ex d IIC T6

Minimum pressure sensor default 1.5 mbarg (0.6"wc)

Range: 0.5 to 5 mbarg (0.2 to 2"wc)

Intermediate sensor/pre-alarm default 5 mbarg (2"wc)

Range: 2 to 10 mbarg (0.8 to 4"wc)

CLAPS sensor default 10 mbarg (4"wc). Range: 5.0 mbarg to 15 mbarg (2"wc to 6"wc)

Relief Valve Lift-Off pressure: default 30mbarg (12"wc)

Minimum: 20mbarg (8"wc), Maximum: 50mbarg (20"wc)

### Certification/Approvals:

IECEX Zone 1 Ex [pxb] ia IIC T4Gb

IECEX Zone 21 Ex [pxb] ia IIIC T100°C Db

ATEX II 2(2) G Ex [pxb] ia IIC T4 Gb

ATEX 112(2),0 Ex [pxb] ia IIIC T100°C Db

INMETRO/TUV Zone 1 Ex [pxb] ia IIC T4 Gb

INMETRO/TUV Zone 21 Ex [pxb] ia IIIC T100°C Db

EAC: RU C-GB.AE61.B

Option: System purge in progress output kit.

12/2020